

NMD 50

Notes and media dispenser

Scaleable solutions for self service automation

The optimisation of cash management calls for specialist experience, resources and truly innovative technology. Across the world, Talaris' cash management solutions are trusted by thousands of organisations to ensure their cash is managed securely and efficiently whilst delivering the ultimate in productivity.

Talaris have in excess of 250 patents granted across 26 countries and are world experts in optimal cash handling solutions. 2,300 Talaris professionals, including over 1,000 service and support staff and 130 business partners cover over 100 countries delivering these solutions - wherever money moves.

The Notes and Media Dispenser NMD 50 provides a single denomination platform, upgradeable to four denominations. It is a tower configuration; friction feed mechanism offering front delivery of banknotes and other value media. With a small footprint, the NMD 50 has been specifically developed for the expanding retail and non-banking sectors and meets the demands for multi-media dispensing such as tickets, stamps, phone cards and vouchers. No planned maintenance is necessary, other than occasional cleaning which means that your machine is available for longer.



The NMD 50 contains three advanced features, unique to Talaris technology: IDD™, HPF™ and SCL™.

Intelligent Double Detection

IDD delivers superb accuracy and consistent detection of doubles even when notes are severely degraded. With IDD, no mechanical adjustments or intervention are required which means that it is ready to use as soon as it is out of the box.

High Performance Feed

HPF provides consistent and durable feeding, reliable handling of notes of all conditions and the ability to process notes without causing damage.

Smart Cassette Logic

SCL offers a fully flexible solution with tamperproof cassettes which can be uniquely identified and individually replenished. Short, long, lockable and non-lockable cassette options are available.

The NMD 50 is available with either a tamper indicating and sealable reject vault or for convenience, a reject tray.

The NMD 50 is designed in accordance with the recommendations of leading International Standards Organisations including RoHS, UL and CE to allow for final approval when installed in complete systems.

Talaris Technology

Talaris' unique technology sets new industry standards

IDD™
intelligent double detection

Offers unbeatable accuracy and consistent detection of doubles even with severely degraded notes. No mechanical adjustments or intervention necessary.

HPF™
high performance feed

Provides consistent and durable feeding, reliable handling of notes of all conditions and the ability to process notes without causing damage.

SCL™
smart cassette logic

A fully flexible solution enabling tamperproof cassettes to be uniquely identified and individually replenished.

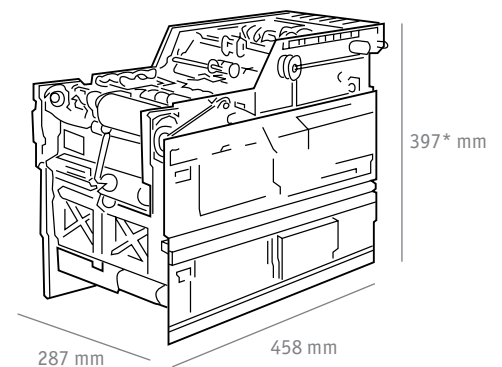

397* mm

287 mm

458 mm

* height shown for 1 denomination, for each additional denomination add 128 mm

Product specification

Speed range	5 notes per second	Operating environment	Temperature: 5 - 50°C, 41 - 122°F Relative humidity: 10 - 90% non-condensing
Document size range	Width: 58 - 85 mm Length: 100 - 181 mm Thickness: 0.06 - 0.18 mm	Dimensions (H x W x D)	397* x 287 x 458 mm *height shown for 1 denomination for each additional denomination add 128 mm
Maximum transaction size	50 ATM fit notes	Weight (without notes)	Standard 1-denomination with cassette: 16.4 kg/36.2 lbs Additional denominations Without cassette: 3.0 kg/6.6 lbs Short cassette: 2.2 kg/4.9 lbs Long cassette: 2.9 kg/6.4 lbs Reject tray: 1.0 kg/2.2 lbs Reject vault: 1.2 kg/2.6 lbs
Capacity	Short cassette: 240 mm or up to 2000 banknotes Long cassette: 340 mm or up to 3000 banknotes	Manufacturing standards and approvals	RoHS, UL, CE
Connectivity	RS232C connection as standard		
Power supply	Operates from DC-only supply* requiring: +12V ±10% Max load current 3A +36V ±10% Max load current 5A *Power supplies are available from Talaris		

Talaris House
Crockford Lane
Chineham Business Park
Basingstoke, Hampshire
RG24 8QZ, UK

T +44 (0)1256 368000
F +44 (0)1256 368002
info@uk.talaris.com
www.talaris.com

talaris™
A former De La Rue company

DS-NMD50-0509

This document is for general guidance only. Talaris Limited is pleased to give detailed specifications of its products in this document. As the Company's products and services are continually being developed it is important for customers to check that the information contained herein includes the latest particulars. Although every precaution has been taken in preparation of this document, the publisher assumes no responsibility for errors or omissions. Neither is any liability assumed for damages resulting from the use of the information contained herein. This document is not part of a contract or licence save insofar as may be expressly agreed. All capacities and throughput figures are subject to note size, note quality and process used. Talaris, IDD, HPF and SCL are trademarks of Talaris Holdings Limited. © Talaris Limited 2009.