

InstaChangeTM (OEM)

Automatic coin dispenser
Intelligent, reliable coin dispensing

The optimisation of cash management calls for specialist experience, resources and truly innovative technology. Across the world, Talaris' cash management solutions are trusted by thousands of organisations to ensure their cash is managed securely and efficiently whilst delivering the ultimate in productivity.

Talaris have in excess of 250 patents granted across 26 countries and are world experts in optimal cash handling solutions. 2,300 Talaris professionals, including over 1,000 service and support staff and 130 business partners cover over 100 countries delivering these solutions - wherever money moves.

The Talaris automatic coin dispenser is truly revolutionary. InstaChange (OEM) represents a major design breakthrough in coin dispensing technology. Its groundbreaking design means an increase in magazine coin capacity of up to 30% compared to competitive dispensers.



Revolutionary universal design

An innovative design keeps moving parts to a minimum resulting in a lower cost of ownership and increased reliability.

The patented and unique coin cassette shape provides greater coin capacity allowing InstaChange to run longer requiring less employee support all day, every day.

The universal base supports a variety of coin set cassettes making it easy for global customers to maximise in-store equipment inventory and minimise service support variations.

Intelligent functionality

InstaChange (OEM) automatically dispenses the right amount of change back to your customer. And unless you tell it otherwise, InstaChange will always dispense the least amount of coin required. If selected, InstaChange (OEM) will intelligently substitute for low channels, further extending availability.

Ease of use

The coin cassette's tear drop design makes for easy transport, storage and placement. InstaChange (OEM) can

be positioned in any direction to ensure the coin cup is within easy reach of the customer.

When InstaChange (OEM) does require refilling, loose or rolled coin is easily loaded into the cassette while it sits either on the universal base or flat on a table. Balancing is aided through the use of colour coded calibration labels.

Interfaces

Each unit ships with standard software drivers (OPOS, JPOS) allowing InstaChange (OEM) to quickly interface with most point of sale systems in use today. InstaChange (OEM) is also fully compatible with the Talaris range of Teller Assist products.

The InstaChange (OEM) is designed to comply with leading International Standards such as RoHS, UL and CE to allow for final approval when installed in complete systems.

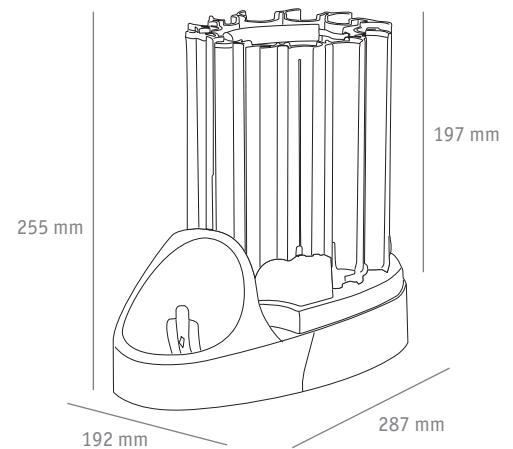

Product specification

Supported coin sets	British sterling Canadian dollar Euro US dollar	Operating environment	Temperature: 5 - 50°C, 41 - 122°F Relative humidity: 10 - 90% non-condensing
Mounting hardware	Each unit ships complete with installation template and bolt down kit	Dimensions (H x W x D)	255 x 192 x 287 mm
Connectivity	RS232C and USB as standard	Weight	Base, cassette (w/cup): 2.8 kg/6.2 lbs Base, cassette (wo/cup): 2.7 kg/5.9 lbs Cassette only: 0.7 kg/1.6 lbs
Power supply	Operates from DC only supply* requiring 12V DC ± 5% Max load current 3.5A * Power supplies are available from Talaris	Options	Additional cassettes
Power consumption	360W	Manufacturing standards and approvals	RoHS, UL, CE

Talaris House
Crockford Lane
Chineham Business Park
Basingstoke, Hampshire
RG24 8QZ, UK

T +44 (0)1256 368000
F +44 (0)1256 368002
info@uk.talaris.com
www.talaris.com

talarisTM
A former De La Rue company

DS-INSTA0EM-0509

This document is for general guidance only. Talaris Limited is pleased to give detailed specifications of its products in this document. As the Company's products and services are continually being developed it is important for customers to check that the information contained herein includes the latest particulars. Although every precaution has been taken in preparation of this document, the publisher assumes no responsibility for errors or omissions. Neither is any liability assumed for damages resulting from the use of the information contained herein. This document is not part of a contract or licence save insofar as may be expressly agreed. All capacities and throughput figures are subject to note size, note quality and process used. Talaris is a trademark of Talaris Holdings Limited and InstaChange is a trademark of Talaris Holdings (US) Inc. © Talaris Limited 2009.