

# Vertera<sup>®</sup> Compact

Teller cash recycler

Small footprint, full featured cash recycler

The optimisation of cash management calls for specialist experience, resources and truly innovative technology. Across the world, Talaris' cash management solutions are trusted by thousands of organisations to ensure their cash is managed securely and efficiently whilst delivering the ultimate in productivity.

Talaris have in excess of 250 patents granted across 26 countries and are world experts in optimal cash handling solutions. 2,100 Talaris professionals, including over 1,000 service and support staff and 130 business partners cover over 100 countries delivering these solutions - wherever money moves.

Vertera Compact is the perfect cash recycler solution for retailers, post offices, casinos and small bank branches to securely hold cashier till funds separated by denomination and currency providing in-store / in-branch deposit, dispense, recycling and preparation for routine cash in transit (CIT).

Installation under shallow counters and small spaces is now a reality for an array of environments. The small footprint allows for easy installation within existing furniture and branch and store layouts where space is limited, minimising the need for furniture redesign, modification or refurbishment. Vertera Compact retains the security, authentication and cash management features found in all Talaris cash recyclers.



Vertera provides a simple, flexible and comprehensive solution designed to improve branch or store efficiency by automating cash count, deposit, verification, authentication and balancing functions. Cashiers are released from time consuming and repetitive tasks to focus on customer engagement and related revenue generating interactions.

- **Increases productivity of frontline staff** by minimising cash handling, counting and sorting processes
- **Creates exceptional client and staff experience** by reducing customer queues and allowing cashiers to concentrate on providing focused personalised services
- **Reduces back office tasks** providing instant reporting tools for start and end of day reconciliation, recorded vault buys and full balance and auditing functions
- **Improves cash management** with immediate visibility of in-branch/store cash levels both within each Vertera unit, and across the branch or store, helping optimise branch cash holding levels and minimising CIT requirements
- **Enhances accuracy** with fitness sorting and authentication detection providing defence from counterfeiters and simple human errors

- **Enhances security** through note-by-note authentication, stored in an integrated CEN L or UL 291 safe ensuring secure storage of cash overnight and reducing or eliminating the need to hold exposed open cash drawers

Vertera Compact offers mid-capacity storage in two efficient small footprint configurations:

- **Vertera Compact 4:** 4 roll storage modules holding up to 2,720 notes. Under counter dimensions:  
CEN L: 660 x 471 x 564mm (H x W x D)  
UL291: 695 x 465 x 564mm (H x W x D)
- **Vertera Compact 6:** 6 Roll storage modules holding up to 2,370 notes. Under counter dimensions:  
CEN L: 660 x 471 x 644mm (H x W x D)  
3mm: 660 x 450 x 592mm (H x W x D)
- The Secure Transfer Concept (STC) option allows for rapid off-sorting of excess cash in preparation for reuse or for pickup by CIT companies. Cash is transferred to a cassette or bag in a fully audited, controlled, hands-off process. Perfect for a single custody cash transfer process

**CashInsight Software and Services Portfolio** options, maximise the value returned from your cash automation investment:

- **CashInsight Assure** software allows Vertera and cashier applications to work together to deliver immediate productivity gains for branch and cash operations
- **CashInsight Bridge** offers remote device monitoring and management allowing optimisation of equipment performance and servicing to reduce down time and service costs
- **CashInsight Inform** provides business intelligence systems to maximise TCR impact on workforce optimisation and cash optimisation

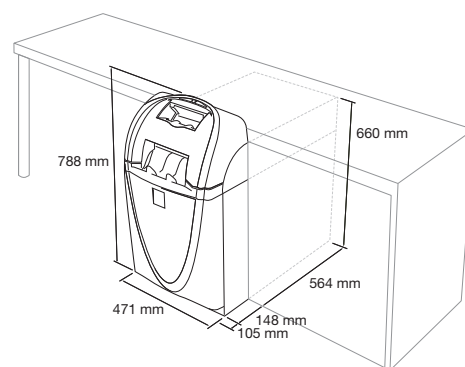

Weight: 320kg  
Weight and dimensions shown are for a 4 RSM model. Data for other configurations will vary, please contact your nearest Talaris office for details.

## Product specification

<b>Roll storage system</b>	4 or 6 roll storage modules (RSM)	<b>Operators</b>	One or two cashiers simultaneously
<b>Capacity</b>	4 RSM – up to 680 notes per module 6 RSM – up to 395 notes per module STC option: additional 1,500 note capacity deposit-only	<b>Detector options</b>	Visible Infrared Ultraviolet Magnetic ink Tape/repair
<b>Safe</b>	4 RSM: CEN L or UL 291 6 RSM: CEN L or 3 mm (designed to SS-EN14450:2005)	<b>Door options (depth)</b>	Normal plain door (shown above): 105mm Drop box door: 170mm STC door: 237mm
<b>Connectivity</b>	RS232 C serial ports x 2 Printer port Option: USB ports, LAN/Ethernet Option: Alarm connectivity	<b>Options</b>	Secure transfer concept (STC) Journal printer Uninterruptible power supply Connectivity to all open network architectures Unfit note drop deposit boxes Sitting or standing height configurations CashInsight Assure teller/cashier application CashInsight Bridge remote monitoring and management
<b>Power supply</b>	100 – 240V AC, 47 – 63 Hz		
<b>Power consumption</b>	1.25 kWh typical average daily power consumption (based on 3,000 note movements per day)		

Talaris House  
Crockford Lane  
Chineham Business Park  
Basingstoke, Hampshire  
RG24 8QZ, UK

T +44 (0)1256 368000  
F +44 (0)1256 368001  
info@uk.talaris.com  
www.talaris.com



DS-VERTERACOMPACT-0911